

## Pressure regulator in RAPAV ventilation systems

# RAPAV-Q

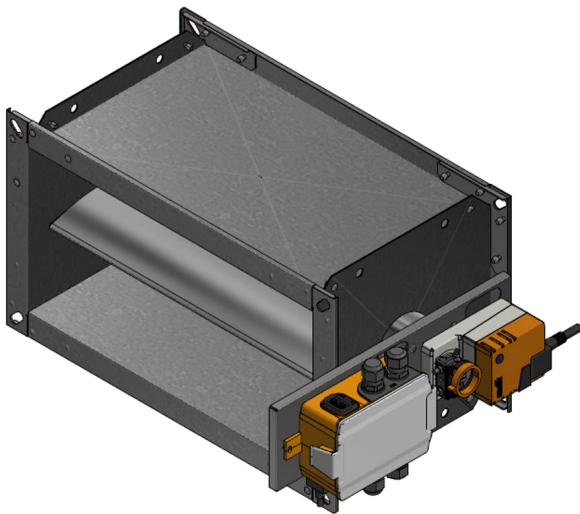

### Description

The RAPAV-Q damper is designed for use in mechanical ventilation systems where the air flow rate depends on the pressure difference between two separate zones (duct / room).

The main components of the controller are made of Z275 galvanised steel sheet. Optionally, it can be manufactured from corrosion-resistant steel grade 1.4301. The connection frames are formed by bending the housing body, ensuring a smooth internal surface and a tight seal. Inside the housing there is a single-plane, profiled control damper without a seal. The control unit is mounted on the regulator housing in a way that allows for thermal insulation of the system. A version of the regulator with factory-fitted 50 mm insulation and a steel sheet jacket is also available.

The pressure regulator consists of three main components:

- the regulator housing with the damper,
- an electronic controller with a pressure transducer – three possible variants – VRU-D3-BAC, VRU-M1-BAC, VRU-M1R-BAC,
- an actuator (nine possible variants).

The kit is assembled to meet individual requirements. Controllers are available in three variants and are selected based on the pressure range, the purity of the air flow, and the location of the pressure regulation (duct or room). Each controller has a built-in sensor (diaphragm-type 'M1', 'M1R' or dynamic 'D3'), which does not require calibration. The controllers can be used in conjunction with external room temperature and CO sensors. Due to its automatic operation, the controller can be installed in any position.

The VRU-D3-BAC controller model features a dynamic sensor, making it suitable for clean air within a pressure differential range of 0–500 Pa.

The VRU-M1-BAC controller model has a built-in diaphragm sensor, allowing it to operate with contaminated air within a pressure differential range of 0–600 Pa.

### Dimensions

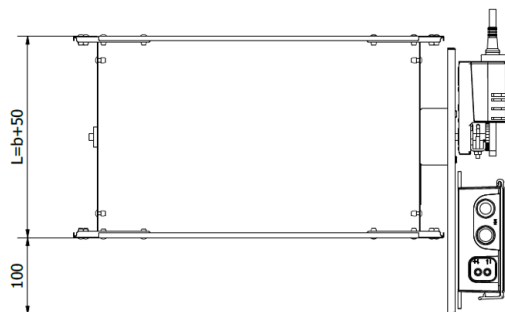
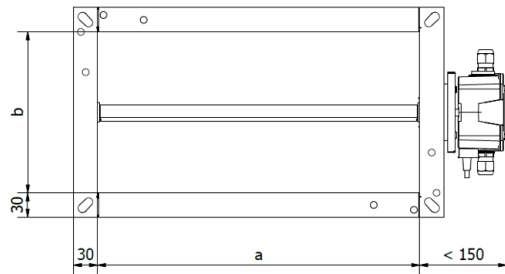

**Table 1. Approximate weight of the device [kg].**

b [mm]	a [mm]									
	100	200	300	400	500	600	700	800	900	1000
100	1,7	2,0	2,4	2,8	3,1	0,0	4,6	5,0	5,5	5,9
200	-	3,1	3,7	4,3	4,9	6,5	7,2	7,9	8,6	9,3
300	-	-	5,3	6,1	6,9	9,2	10,2	11,2	12,1	13,1

**Table 2. Length L for individual regulator dimensions [mm].**

b [mm]	A [mm]									
	100	200	300	400	500	600	700	800	900	1000
100	150	150	150	150	150	150	150	150	150	150
200	-	250	250	250	250	250	250	250	250	250
300	-	-	350	350	350	350	350	350	350	350

The VRU-M1R-BAC controller is used to measure the pressure difference between rooms. It is used, for example, in laboratories, operating theatres and isolation wards where a constant positive or negative pressure must be maintained between rooms, within an operating range of -75 to +75 Pa. It can be used with contaminated air. The controller can be used in conjunction with an independent door-opening sensor.

The main criteria for selecting an actuator are operating time, torque and safety function. Nine types of actuators are available to complete the set. Torque ranges from 4 to 20 Nm. The standard operating time is 120 seconds; high-speed actuators with operating times between 2.5 and 4 seconds are also available. It is also possible to select actuators with a safety function (with a spring).

## Pressure regulator in RAPAV ventilation systems

# RAPAV-Q

Communication tools: NFC (Belimo Assistant 2 app for Android and iOS), service port (PC-Tool), MP connection ZTH EU / LINK.10

**Table 1. Universal series controllers**

TYPE	Sensor type	Measuring range	Application			
			VAV Regulators	Pressure measurement in the duct	Pressure measurement in the room	For contaminated air
VRU-D3-BAC	Dynamic D3	0-500Pa	YES	YES	NO	NO
VRU-M1-BAC	Membrane M1	0-600 Pa	YES	YES	NO	YES
VRU-M1R-BAC	Membrane M1R	Od -75 do 75 Pa	YES	NO	YES	YES

### Construction of the Universal series controller

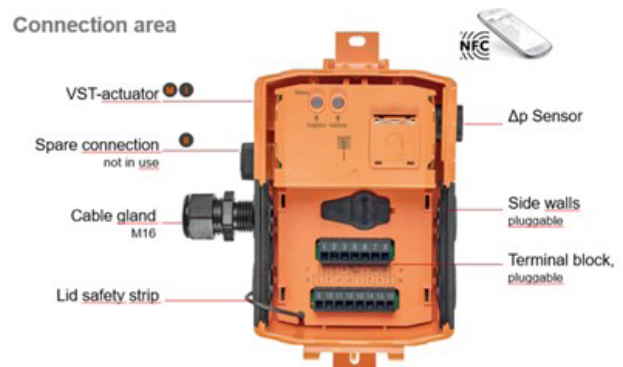

#### Advantages and application of a membrane sensor (static):

- Applicable for contaminated air
- Shockproof
- Does not require calibration
- Long-term stability (temperature changes, age)
- Can be mounted in any position

#### Advantages of a dynamic sensor:

- Applicable for clean air
- Does not require calibration
- Can be mounted in any position

## Pressure regulator in RAPAV ventilation systems

**RAPAV-Q****Table 2. Automatic control of regulators:**

1-	Duct pressure 0...500 Pa, comfort range (not contaminated media), standard actuators	VRU-D3-BAC + VST, rotary actuator, standard (LM/NM*24A-VST)
2-	Duct pressure 0...600 Pa, comfort range as well as contaminated media, standard actuators	VRU-M1-BAC + VST, rotary actuator, standard (LM/NM*24A-VST)
3-	Room pressure -75...75 Pa, standard actuators	VRU-M1R-BAC + VST, rotary actuator, standard (LM/NM*24A-VST)
SAFE-1-	Duct pressure 0...500 Pa, comfort range (not contaminated media), actuators with mechanical fail-safe	VRU-D3-BAC + VST, rotary actuator, with spring (LF24/NF*24A-VST)
SAFE-2-	Duct pressure 0...600 Pa, comfort range as well as contaminated media, actuators with mechanical fail-safe	VRU-M1-BAC + VST, rotary actuator, with spring (LF24/NF*24A-VST)
SAFE-3-	Room pressure -75...75 Pa, actuators with mechanical fail-safe	VRU-M1R-BAC + VST, rotary actuator, with spring (LF24/NF*24A-VST)
FAST-1-	Duct pressure 0...500 Pa, comfort range (not contaminated media), very fast running actuators	VRU-D3-BAC + VST, rotary actuator, fast (LMQ/NMQ*24A-VST)
FAST-2-	Duct pressure 0...600 Pa, comfort range as well as contaminated media, very fast running actuators	VRU-M1-BAC + VST, , rotary drive, fast (LMQ/NMQ*/NKQ24A-VST)
FAST-3-	Room pressure -75...75 Pa, very fast running actuators	VRU-M1R-BAC + VST, rotary actuator, fast (LMQ/NMQ*24A-VST)

**How to order****Marking example**

Product code:

**A - material type**

- default: galvanized steel
- K - 1.4301/304 steel

**B - Insulation**

- default: not insulated
- I - insulation with external shield, thickness: 50mm

**C - nominal dimension a-b (according to Table 1)****D - type of automatic control (according to Table 4)**

- 1

- 2

- 3

- SAFE1

- SAFE2

- SAFE3

- FAST1

- FAST2

- FAST3

**P<sub>nom</sub> - nominal pressure**

(nominal pressures given in Table 4.

may vary depending on selected automatic control system)

-none - maximum factory pressure range offered by the wybraną automatykę

- F - type of communication

- none - 2...10 [V]

- 1- 0...10 [V]

MP- MP BUS

MOD- Modbus

BAC - BACnet

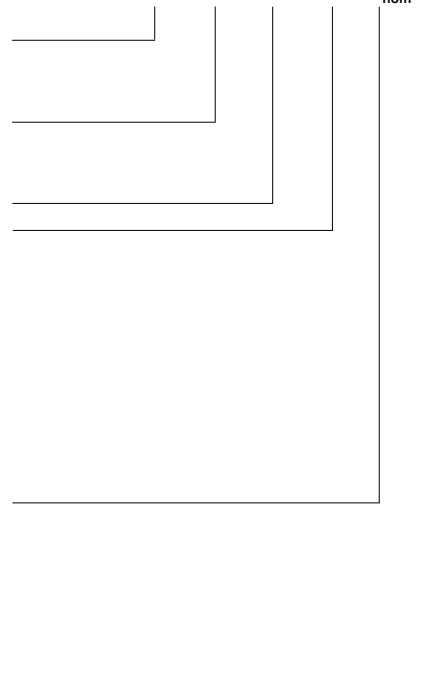
RAPAV-Q - aaa - bbb - ccc - ddd - P<sub>nom</sub> - F

The manufacturer reserves the right to introduce changes.

## Pressure regulator in RAPAV ventilation systems

# RAPAV-Q

**Note!** In the event that narrower pressure measurement range is required, the customer can, after installation of the regulator, independently change the P'max and P'min pressure ranges using the Belimo assistant App and the NFS function. P'max value can be set by the customer in the range of 20-100% of P'nom, and the P'min value = 0-100% of P'max. Default setting: P'max=100%P'nom, P'min=0%P'nom (the broadest possible measurement range). Do not change the direction of rotation of the actuator.

Additional information that can be provided when placing an order: place of installation of the regulator / name of the building (max. 16 characters), position of the regulator in the system / name of the room.

After installing the regulator in the facility, a qualified person has to set whether the device is to work on supply or exhaust using one of the service tool. The VRU-M1R-BAC controller also requires setting to negative or positive pressure. Default setting is set to supply and positive pressure.

### *Characteristics*

- The insulation of adjusting damper is classified as class 4 as per EN-1751:1998 (option),
- Casing leakage is class C as per EN-1751:1998,
- Operating temperatures range from 0 to 40 or 50 [°C] (depending on the actuator used),
- Differential pressure ranges from -75 to 75, 0-500 [Pa] or 0-600 [Pa] depending on the selected controller.

### *Assembly instructions*

1. Impulse cables to the pressure sensor must be placed in the given zone at the place representative in terms of pressure measurement,
2. Recommended maximum length of pulse cables-20 linear meters. Use of longer cables will lead to an increase in measuring error,
3. Pulse cables with hose sockets are not included with the regulatorhe regulator.

# RAPAV-Q

## Sound ratings

Sound power level emitted into the system for various damper settings.

DN	b	v	LWA [dB(A)]									
			a									
			[mm]									
[Pa]	[mm]	[m/s]	100	200	300	400	500	600	700	800	900	1000
50	100	2	30	33	35	36	37	38	38	39	40	40
		4	39	42	43	45	46	46	47	48	48	49
		6	43	46	48	49	50	51	52	52	53	53
		8	47	50	52	53	54	55	55	56	56	57
		10	50	53	54	56	57	57	58	59	59	60
		12	52	55	57	58	59	60	61	61	62	62
	200	2	-	34	36	37	38	39	39	40	40	41
		4	-	43	45	46	47	48	48	49	49	50
		6	-	48	50	51	52	53	53	54	54	55
		8	-	51	53	54	55	56	57	57	58	58
		10	-	54	56	57	58	59	60	60	61	61
		12	-	57	59	60	61	62	63	63	64	64
	300	2	-	-	35	37	38	38	39	40	40	41
		4	-	-	45	46	47	48	49	49	50	50
		6	-	-	50	51	52	53	53	54	55	55
		8	-	-	53	55	56	56	57	58	58	59
		10	-	-	57	58	59	60	60	61	61	62
		12	-	-	60	61	62	63	63	64	64	65
100	100	2	36	39	41	42	43	44	45	45	46	46
		4	44	47	49	50	51	52	52	53	53	54
		6	49	52	54	55	56	57	58	58	59	59
		8	52	55	57	58	59	60	61	61	62	62
		10	55	58	59	61	62	62	63	64	64	65
		12	57	60	62	63	64	65	65	66	66	67
	200	2	-	40	42	43	44	45	46	46	47	47
		4	-	48	50	51	52	53	54	54	55	55
		6	-	54	56	57	58	59	59	60	60	61
		8	-	57	59	60	61	62	62	63	63	64
		10	-	59	61	62	63	64	65	65	66	66
		12	-	62	64	65	66	67	67	68	68	69
	300	2	-	-	43	44	45	46	46	47	48	48
		4	-	-	50	52	53	53	54	55	55	56
		6	-	-	56	57	58	59	60	60	61	61
		8	-	-	59	61	62	62	63	64	64	65
		10	-	-	62	63	64	65	66	66	67	67
		12	-	-	65	66	67	68	68	69	69	70

# RAPAV-Q

## Sound ratings

Sound power level emitted into the system for various damper settings.

DN	b	v	LWA [dB(A)]									
			a									
			[mm]									
[Pa]	[mm]	[m/s]	100	200	300	400	500	600	700	800	900	1000
150	100	2	40	43	45	46	47	48	49	49	50	50
		4	47	50	52	53	54	55	56	56	57	57
		6	52	55	57	58	59	60	60	61	62	62
		8	56	59	60	62	63	63	64	65	65	66
		10	58	61	63	64	65	66	66	67	67	68
		12	60	63	65	66	67	68	68	69	69	70
	200	2	-	45	47	48	49	50	50	51	51	52
		4	-	52	54	55	56	57	57	58	58	59
		6	-	57	58	60	61	61	62	63	63	64
		8	-	60	62	63	64	65	66	67	67	67
		10	-	63	65	66	67	68	68	69	69	70
		12	-	65	67	68	69	70	70	71	71	72
	300	2	-	-	47	48	49	50	51	51	52	52
		4	-	-	54	55	56	57	57	58	59	59
		6	-	-	59	60	61	62	63	63	64	64
		8	-	-	63	65	66	66	67	68	68	69
		10	-	-	66	67	68	69	69	70	70	71
		12	-	-	68	69	70	71	71	72	72	73
200	100	2	44	47	48	50	51	52	52	53	53	54
		4	49	52	54	55	56	57	58	58	59	59
		6	54	57	59	60	61	62	63	63	64	64
		8	58	61	63	64	65	66	66	67	67	68
		10	60	63	65	66	67	68	69	69	70	70
		12	62	65	67	68	69	70	71	71	72	72
	200	2	-	48	50	51	52	53	54	54	55	55
		4	-	54	56	57	58	59	60	60	61	61
		6	-	59	61	62	63	64	64	65	65	66
		8	-	63	64	66	67	67	68	69	69	70
		10	-	65	67	68	69	70	71	71	72	72
		12	-	67	69	70	71	72	73	73	74	74
	300	2	-	-	50	51	52	53	54	54	55	55
		4	-	-	56	58	59	59	60	61	61	62
		6	-	-	62	63	64	65	65	66	66	67
		8	-	-	65	67	68	69	69	70	70	71
		10	-	-	68	69	70	71	72	72	73	73
		12	-	-	70	71	72	73	74	74	75	75

# RAPAV-Q

## Sound ratings

Sound power level emitted into the system for various damper settings.

DN	b	v	LWA [dB(A)]									
			a									
			[mm]									
[Pa]	[mm]	[m/s]	100	200	300	400	500	600	700	800	900	1000
250	100	2	46	49	51	52	53	54	55	55	56	56
		4	51	54	56	57	58	59	60	60	61	61
		6	56	59	61	62	63	64	64	65	65	66
		8	59	62	64	65	66	67	68	68	69	69
		10	62	65	67	68	69	70	71	71	72	72
		12	64	67	69	70	71	72	73	73	74	74
	200	2	-	51	53	54	55	56	56	57	57	58
		4	-	56	58	59	60	61	61	62	63	63
		6	-	61	62	64	65	65	66	67	67	68
		8	-	64	66	67	68	69	70	70	71	71
		10	-	67	69	71	71	72	73	74	74	74
		12	-	69	71	72	73	74	75	75	76	76
	300	2	-	-	53	54	55	56	57	57	58	58
		4	-	-	58	60	61	61	62	63	63	64
		6	-	-	63	65	66	66	67	68	68	69
		8	-	-	67	68	69	70	71	71	72	72
		10	-	-	70	71	72	73	74	74	75	75
		12	-	-	72	73	74	75	76	76	77	77
500	100	2	55	58	60	61	62	63	64	64	65	65
		4	58	61	62	64	65	65	66	67	67	68
		6	61	64	66	67	68	69	70	70	71	71
		8	65	68	69	71	72	72	73	74	74	75
		10	67	70	72	73	74	75	76	76	77	77
		12	69	72	74	75	76	77	78	78	79	79
	200	2	-	60	62	63	64	65	66	66	67	67
		4	-	63	64	66	67	67	68	69	69	70
		6	-	66	68	69	70	71	72	72	73	73
		8	-	70	72	73	74	75	75	76	76	77
		10	-	72	74	75	76	77	78	78	79	79
		12	-	75	77	78	79	80	80	81	81	82
	300	2	-	-	63	64	65	66	67	67	68	68
		4	-	-	65	67	68	68	69	70	70	71
		6	-	-	69	70	71	72	73	73	74	74
		8	-	-	72	74	75	75	76	77	77	78
		10	-	-	75	76	77	78	79	79	80	80
		12	-	-	78	79	80	81	81	82	82	83

## RAPAV-Q

### Servomotor specification

**Table 1. Specification of Universal series regulators**

RAPAV can be supplied with actuators with standard timing of motion or with fast actuators.

Specification	VRU-D3-BAC	VRU-M1-BAC	VRU-M1R-BAC
Rated voltage	AC/DC 24V, 50/60Hz, AC 19.2...28.8 V / DC 21.6...28.8 V		
Power consumption	1,5 W		
Communications	BACnet MS/TP, Modbus RTU, MP-Bus		
Working range Y/ Variable Y working range	2-10 V / 0,5-10 V		
Feedback signal U	Max 0,5 mA Options: flow, Δp, position		Max 0,5 mA Options: Δp, position
Variable U Feedback signal	0...10 V Start point 0...8 V End point 2...10 V		
Measurement accuracy	±1 [Pa] in the range of 0...20 [Pa], ±5% in the range of 20...500 [Pa]	-	-
Maximum duct pressure	1500 Pa	1500 Pa	-
Elevation reduction	Adapted for installation at 0-3000 m.n.p.m. above sea level		
Specification of measured air	Temperature 0...+50°C, humidity 5...95% r.H., no condensation		
Connection pressure hoses	5.3mm diameter, max. 20m of length for the measurement of duct pressure (inner diameter 5 mm)	Diameter 5.3 mm (inner diameter 5mm)	
Casing insulation class	IP42		
Storage and transport temperature	-20...80°C		
Maintenance	Maintenance-free		
Weight	0,34 kg		

- Controllers can work with room temperature sensors, CO2 sensors
- VRU-M1R-BAC can operate with the 'door switch' sensor
- For VRU-D3-BAC, the maximum length of measuring tubes is 20m, for longer tubes, the VRU-M1-BAC is recommended

**Table 2. Actuator Specification**

Specification	LM24A-VST	NM24A-VST	SM24A-VST	LMQ24A-VST	NMQ24A-VST	NMQ24A-VST	LF24-VST	NF24A-VST	SF24A-VST
Rated voltage (from VRU regulator...)	AC/DC 24V 50/60 Hz								
Power consumption (in operation/idle)	1/ 0,4 W	2/ 0,4 W	2/ 0,4 W	13/2 W	13/2 W	11 / 3 W	2,5/1 W	5/ 2,5 W	8,5 / 3,5 W
Protection class	III Safe voltage - low								
Torque	5 Nm	10 Nm	20Nm	4 Nm	8 Nm	6 Nm	4 Nm	10 Nm	20 Nm
Motion time	120 s			2,5 s	4 s		120 s		
Safety feature	No					Yes			
Casing insulation class	IP 54								
Electromagnetic compatibility	CE as per 2014/30/WE								
Ambient temperature	-30...50 °C			-30...40 °C			-30...50 °C		
Ambient humidity	Max. 95% relative humidity, no condensation								
Manual setting	Button with an option to lock					Button	No	Using a crank and a lock switch	
Maintenance	Maintenance-free								
Mass	0,5 kg	0,8 kg	0,5 kg	0,85 kg	0,90 kg	1,1 kg	1,9 kg	1,9 kg	2,2 kg

## Pressure regulator in RAPAV ventilation systems

**RAPAV-Q***Operating diagram*

1. Measurement of the pressure difference in a duct on a measuring element (on a flange/reductor)
2. Measure the pressure difference between the duct and outside the duct

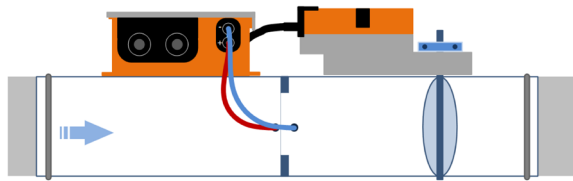
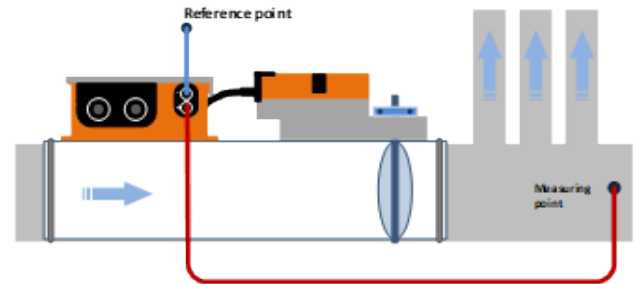
Volume flow VAV/CAV Channel / ribbon pressure STP 

\*Pre-installed jumpers 2-4.  
Delete during remote specification of the set-point.

- VRU-D3-BAC 0...500 Pa (max. 20 m)
- VRU-M1-BAC 0...600 Pa

3. Measurement of the pressure difference between two rooms or between a room and another reference point; can operate with positive and negative pressures

Control function: Room pressure

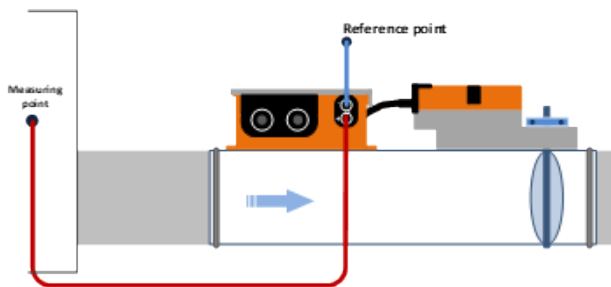

- VRU-M1R-BAC -75...75 Pa
- L/N/SM24A-VST, N/SF24A-VST

# Pressure regulator in RAPAV ventilation systems

## RAPAV-Q

### Connections diagram

#### Analogue contro:

AC/DC 24 V, modulating (VAV)

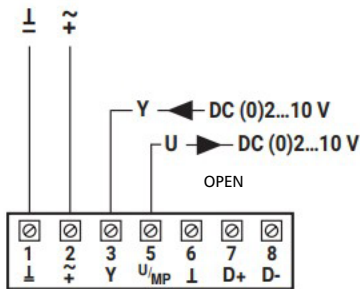

#### Override control z1

Contact 11-9 = Motor STOP  
Contact 11-10 = Damper OPEN

#### Override control z2

Contact 12-13 = Damper CLOSED  
Contact 12-14 = MAX

11/12 uncoated = priority rule  
a/b/c/d/e

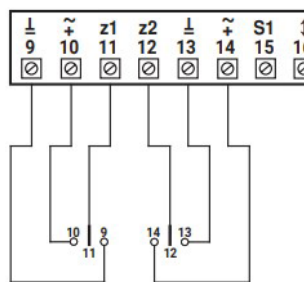

#### Modulation

VAV and pressure applications: Min ... Max

#### Adjustment levels

- VAV and pressure applications
- Min.
- Max
- Damper CLOSED
- Damper open
- (Motor-stop)

No half-wave circuit (diodes)

24 V AC/DC Step control (CAV)

Contact 2-3 = MAX 3 uncoated = MIN  
Contact 1-3 = CLOSE (Mode 2...10 V)

MIN (Mode 0...10 V)

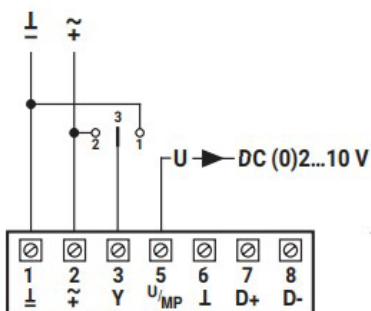

#### Override control z1

Contact 11-9 = Motor STOP  
Contact 11-10 = Damper OPEN

#### Override control z2

Contact 12-13 = Damper CLOSED  
Contact 12-14 = MAX

11/12 uncoated = priority rule  
a/b/c/d/e

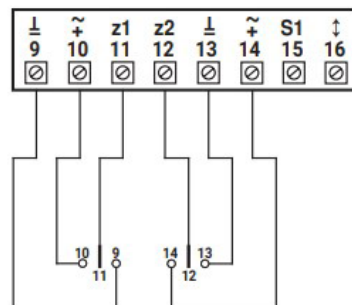

#### Modulation

VAV and pressure application: Min / Max

#### Adjustment levels

- VAV application and Print
- min
- max
- Flap closed
- Flap OPEN
- (motor stops)
- )

No half-wave circuit (diodes)

# Pressure regulator in RAPAV ventilation systems

## RAPAV-Q

### BACnet / Modbus RTU control:

BACnet MS/TP / Modbus RTU

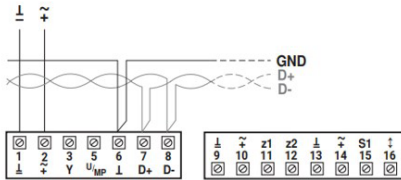

Connection passive Sensor (bus operation)



1)	2)
200 Ω...2 kΩ	0.5 Ω
2 kΩ...10 kΩ	2.7 Ω
10 kΩ...55 kΩ	14.7 Ω



BACnet MS/TP / Modbus RTU with analog setpoint (hybrid mode)

